

PERSONAL V-SCOPE™

Model VM-2000

**A Waveform Monitor/Vector Scope for
PC Compatible Expansion
Slots**

User's Manual

Release Version 1.0

First Edition: January, 1992



DIGITAL
PROCESSING SYSTEMS INC.

PERSONAL V-SCOPE™

Model VM-2000

**A Waveform Monitor/Vector Scope for
PC Compatible Expansion
Slots**

User's Manual

Release Version 1.0

First Edition: January, 1992



DIGITAL
PROCESSING SYSTEMS INC.

Digital Processing Systems Inc.
55 Nugget Ave., Unit #10, Scarborough,
Ontario, Canada M1S 3L1
Phone: (416) 754-8090
Fax: (416) 754-7046

DPS Personal V-SCOPE™ Table of Contents
--

Chapter 1: Introduction	1-1
Chapter 2: Configuration	2-1
DIP Switches:	2-1
Switch 1 : Baud Rate.....	2-1
Switch 2-4 : Power Up Mode	2-1
W/F Output Mode Jumper:	2-3
Chapter 3: Installation.....	3-1
Making the Serial Connection:	3-1
Systems with DPS Personal TBC-II's:	3-1
AMIGA Systems without Personal TBC-II's:.....	3-1
IBM PC Systems without Personal TBC-II's:.....	3-2
Chapter 4: Video Connections	4-1
1 - Serial Data Input.....	4-1
2 - NTSC Video Input	4-1
3 - Video 'OK' LED	4-1
4 - Buffered Video Output	4-1
5 - Superimpose Output	4-1
6 - Full Time Output.....	4-3
Interfacing Examples.....	4-3
V-SCOPE Without Dedicated Monitor	4-3
V-SCOPE With Dedicated Monitor	4-4
Chapter 5: V-SCOPE Control Software	5-1
Installation	5-1
Integrated V-SCOPE and TBC-II Control	5-1
Stand Alone V-SCOPE Control Program.....	5-1
1 - Waveform Mode Select Gadget	5-2
2 - Vector Mode Select Gadget.....	5-2
3 - Waveform + Vector Overlay Gadget.....	5-2
4 - Waveform + Vector Split Screen Gadget.....	5-2
5 - Flat/Low Pass Cycle Gadget.....	5-3
6 - 1-H/2-H Waveform Cycle Gadget.....	5-3

Chapter 5: V-SCOPE Control Software (Cont'ed)	
7 - Superimpose Enable Gadget	5-3
8 - Trace Mode Cycle gadget	5-3
9 - Trace Freeze Gadget	5-4
10 - Variable Trace Rate Slider	5-4
11 - Variable Trace Value	5-4
Chapter 6: Personal TSG Software	6-1
Installation	6-1
Running the Personal TSG Software	6-1
Toaster Vers 1.x vs Vers 2.x	6-1
Displaying the Test Signals	6-2
List of Personal TSG Test Signals	6-2
Chapter 7: Video Measurements.....	7-1
V-SCOPE Waveform Mode.....	7-1
IRE Units	7-1
The Horizontal Blanking Interval	7-1
The Active Video Interval.....	7-3
Full Field Color Bars Signal.....	7-3
SMPTE Color Bars Signal	7-5
Using SMPTE Color Bars for Monitor Alignment.....	7-5
The Multi-Burst Test Signal	7-7
The Pulse and Bar Test Signal.....	7-9
The Convergence Grid Signal	7-9
V-SCOPE Vector Scope Mode	7-11
V-SCOPE Waveform/Vector Scope Overlay Mode.....	7-13
V-SCOPE Waveform/Vector Scope Split Screen Mode	7-14
Processing Live Video.....	7-15
Chapter 8: Specifications.....	8-1
Appendix A: Using an Expansion Serial Board	A-1
Commadore® A2232 Serial Card.....	A-1
ASDG® Dual Port Serial Board	A-2
Appendix B: Troubleshooting	B-1
General	B-1
V-SCOPE Software.....	B-1

Appendix C: V-SCOPE Software Protocol	C-1
Electrical Interface	C-1
Protocol	C-1
System Exclusive Byte.....	C-1
V-SCOPE ID Byte.....	C-2
V-SCOPE Address Byte.....	C-2
V-SCOPE Function Select/Data Byte	C-2
V-SCOPE ARexx Interface	C-3
Appendix D: FCC Compliance Statement	D-1
Appendix E: Warranty	E-1
Limitations.....	E-1
Warranty Service	E-2

Chapter One : Introduction

The Personal V-SCOPE is a combination waveform monitor and vector scope which provides precise real time monitoring of video signals. The V-SCOPE produces a digitally synthesized waveform/vector display, including graticules, which can be displayed on any video monitor. The V-SCOPE features a variety of display modes including simultaneous waveform and vector displays in either overlay or split screen modes.

The Personal V-SCOPE card is designed to work in any IBM PC® or 100% compatible 8 or 16-bit type expansion slot. The card obtains its power from the expansion slot, but DOES NOT require any other buss signals. This allows the card to be used in an AMIGA® PC slot WITHOUT requiring an AMIGA PC bridgeboard.

The various display modes and features of the V-SCOPE are controlled via software. The software communicates with the V-SCOPE using the RS-232 serial data port on the host computer. Serial data is input to the V-SCOPE via the rear panel RJ-14 connector, or the internal serial data headers. The V-SCOPE may be daisy chained with the DPS Personal TBC-II allowing a single serial port to control multiple TBC's as well as the V-SCOPE.

The Personal V-SCOPE has a single video input, a buffered video output, a waveform/vector superimpose output, and a full-time waveform/vector output.

Chapter Two : Configuration

Before installing the Personal V-SCOPE in your computer, it may be necessary to move some of the jumpers or DIP switches to configure the card for your application. Refer to figure 2-1 for the location of the jumpers and DIP switches.

DIP Switches:

The four position DIP switch bank located at the front of the card is used to set up the communications baud rate, and power-up default mode.

Switch 1 : Baud Rate

This switch determines the serial data baud rate and must be set as indicated in the table below:

Up	= 31.25 KBPS (AMIGA)
Down	= 9600 BPS (IBM PC)

Note: If you are using the card in an AMIGA and are using an expansion serial card (such as the Commadore® A2232) then you must select 9600 BPS mode.

Switch 2-4 : Power Up Mode

These switches determine the V-SCOPE display mode that will be entered when the card is power cycled (Note: Not all combinations of operating modes can be selected, however, full mode selection is provided when using the V-SCOPE control software).

<u>Switch-2</u>	<u>Switch-3</u>	<u>Switch-4</u>	<u>Power Up Mode</u>
Up	Up	Up	Full screen waveform (1-H)
Down	Up	Up	Full screen waveform (2-H)
Up	Down	Up	Full Screen vector
Down	Down	Up	Waveform (1-H)/Vector overlay
Up	Up	Down	Waveform (2-H)/Vector overlay
Down	Up	Down	Waveform/Vector split screen
Up	Down	Down	Waveform (LPF)/Vector split screen
Down	Down	Down	Full screen waveform (LPF)

Figure 2-1. Personal V-SCOPE DIP Switches & Jumpers

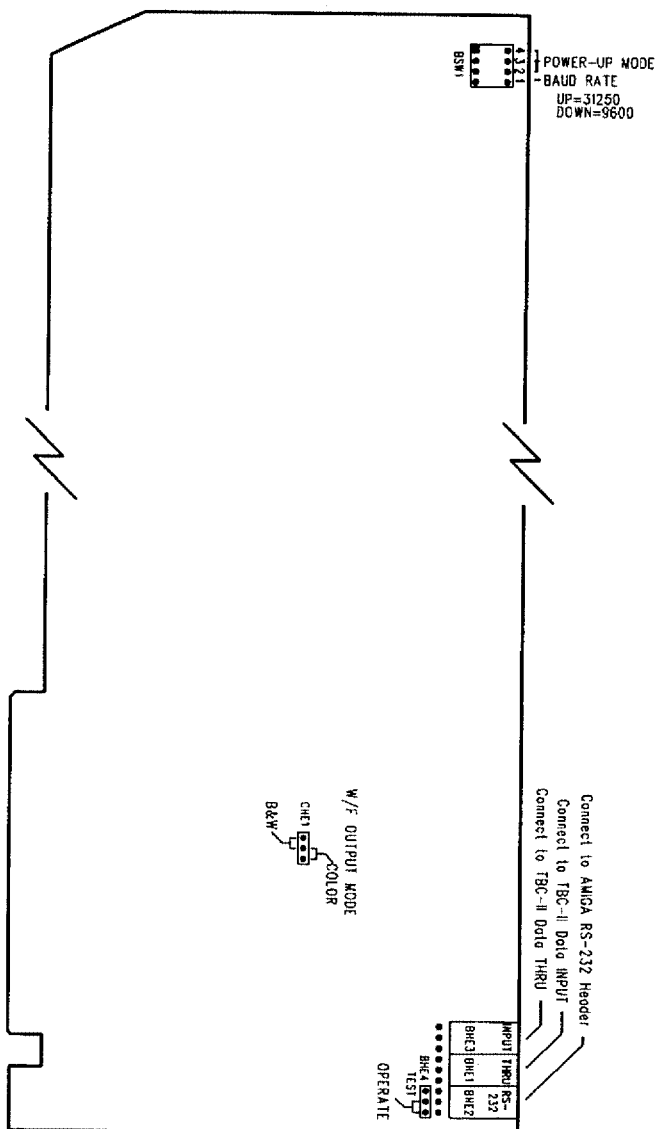

W/F Output Mode Jumper:

The W/F output mode jumper (CHE1 on the card) is used to select either color or black and white mode for the superimpose and full-time V-SCOPE outputs. Color mode produces color video in the background of both the superimpose and full-time outputs, while black and white yields a monochrome background video. The color mode is factory default. If you are using the V-SCOPE with a dedicated monochrome monitor, or want to improve the quality of the synthesized V-SCOPE graphics (when viewed on a color monitor) then move this jumper to the black and white position.

Chapter Three : Installation

This section describes how to install the Personal V-SCOPE card in your computer. The installation procedure is similar for both IBM and AMIGA type PCs (using the PC compatible expansion slots).

1. Turn off the computer, and disconnect the power cord.
2. Refer to the instructions accompanying your computer for information on how to remove the cover.
3. The computer should contain a number of expansion slots. For the AMIGA PC, use the IBM bridgeboard slots. For IBM compatible PCs, select any convenient empty slot for the V-SCOPE card. If the slot is covered, remove the screw that holds the expansion slot cover and remove the cover.
4. Insert the card into the expansion slot on an angle, so that the four BNC connectors exit the rear panel of the computer, and then slide the front of the card into the card guide. Lock the board in place by fastening the retaining bracket with the screw from the slot cover.

Making the Serial Connection:

If you want to use the control software to operate your V-SCOPE, then you must use one of the following methods to connect the V-SCOPE card to the serial port of your computer.

Systems with DPS Personal TBC-II's:

If you have one or more DPS Personal TBC-II's in your system, then use the short (3-inch, 3-wire) cable provided with the V-SCOPE to connect the V-SCOPE serial data INPUT connector (see figure 2-1) to the serial data THRU connector on your last TBC-II.

AMIGA Systems without Personal TBC-II's:

If you are using an AMIGA type computer, and do not have a Personal TBC-II installed, then you must connect the V-SCOPE to the AMIGA serial port using either the long (12-inch, 3-wire) internal serial data cable provided, or using the external DB-25 to RJ-14 data cable. (Note: If you are using the V-SCOPE with an expansion serial card, then you must use the external DB-25 to RJ-14 cable, see appendix A for details).

If you want to use the internal serial cable method, perform the following steps:

1. Locate the internal serial data (12-inch, 3-wire) cable provided with the V-SCOPE card.
2. Refer to figure 3-1, and connect one end of this cable to the AMIGA internal serial data header (Note: this header is located on the AMIGA motherboard, near the rear panel serial DB-25 connector).

Figure 3-1 Internal AMIGA Serial Data Connection

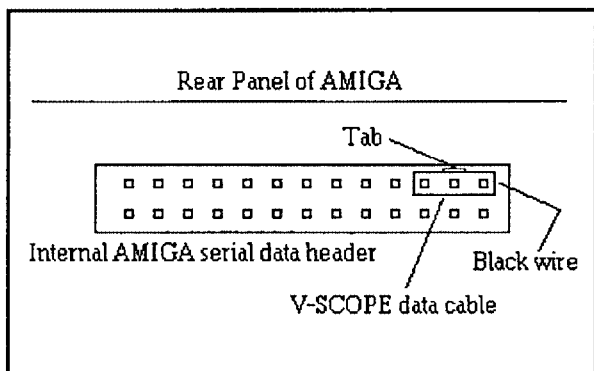

3. Connect the other end of this cable to the 3-pin header on the V-SCOPE labeled RS-232 (See figure 2-1).

If you want to use the external DB-25 to RJ-14 cable, the follow the instructions below for IBM PC systems.

IBM PC Systems without Personal TBC-II's:

Connect the DB-25 end of the DB-25 to RJ-14 cable to the serial port on your computer. Connect the RJ-14 end to the RJ-14 connector on the V-SCOPE card.

Chapter Four : Video Connections

This section describes how to interface the Personal V-SCOPE card with other video equipment in your system. Figure 4-1 shows the location and function of the V-SCOPE I/O connectors and LED.

1 - Serial Data Input

This connector is used with the DB-25 to RJ-14 cable provided, to connect to the computers RS-232 port. (Note that AMIGA users and users with existing DPS Personal TBC-II's may use the internal serial data headers, see chapter three).

2 - NTSC Video Input

This BNC type connector is used to input composite NTSC video to the Personal V-SCOPE. It is normally connected to the program video output of your video switcher. The video signal input on this connector will appear at the buffered video output, and in the background on both the superimpose and full-time outputs.

3 - Video 'OK' LED

This LED will light when a valid NTSC signal is applied to the video input connector.

4 - Buffered Video Output

This BNC type connector provides a buffered video output signal, which is a copy of the video signal applied to the video input connector. It is normally connected to your record VTR.

5 - Superimpose Output

This BNC type connectors output is determined by the V-SCOPE control software. When the superimpose mode is selected, this output will contain the synthesized waveform/vector display superimposed on the input video signal. When the superimposed mode is not selected, this output will be a copy of the video input signal. If you are not using a separate, dedicated monitor (connected to the full-time V-SCOPE output), then this output should be connected to your program video monitor.

Figure 4-1 Personal V-SCOPE I/O Connectors

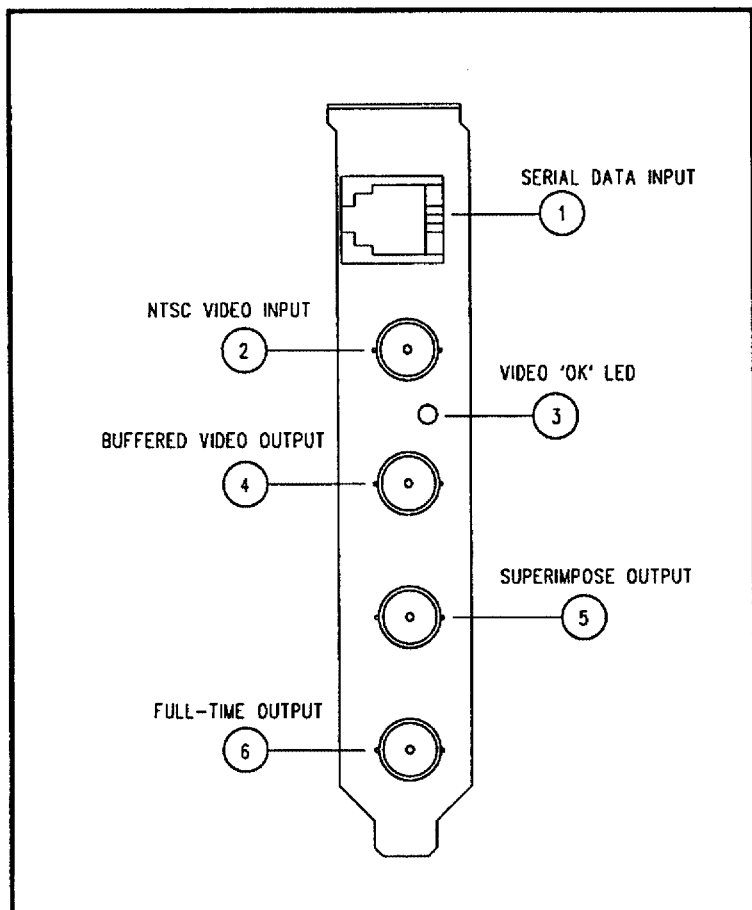

6 - Full Time Output

This BNC type connectors output contains the synthesized waveform/vector display superimposed on the input video signal at all times. This output is normally connected a video monitor (if one is available) which is dedicated to displaying the V-SCOPE waveform/vector information.

Interfacing Examples

The following examples illustrate the correct method of interfacing the Personal V-SCOPE with a video switcher, a record VTR, and picture monitors. Note, if you are using the V-SCOPE with the NewTek® Video Toaster®, then DO NOT connect the V-SCOPE to the Video Toaster PREVIEW output. This output is not correctly filtered, and will produce misleading readings when displayed on the V-SCOPE. Instead, always use the program output, which is properly filtered.

V-SCOPE Without Dedicated Monitor

Figure 4-1 below illustrates how to interface the V-SCOPE with a video switcher a record VTR and a program monitor. Note that the record VTR is connected to the V-SCOPE video output, while the program monitor is connected to the superimpose output. This allows waveform/vector information to be displayed on the program monitor (when enabled via the control software) while not interfering with the record VTR signal.

Figure 4-1 VSCOPE without dedicated monitor

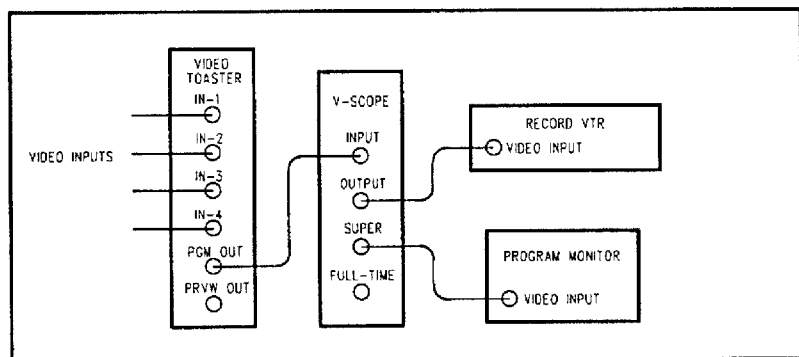

V-SCOPE With Dedicated Monitor

Figure 4-2 below illustrates how to interface the V-SCOPE with a video switcher a record VTR a program monitor and a dedicated V-SCOPE monitor. The dedicated V-SCOPE monitor may be any composite NTSC type video monitor. When you are using a dedicated V-SCOPE monitor, you have the option of moving the W/F mode jumper (see chapter 2) to the black and white position. This will remove the color burst from the V-SCOPE superimpose and dedicated outputs, which will make these outputs appear in monochrome. This will improve the quality of the V-SCOPE graphics. In this example, both the program monitor and the record VTR are connected to the V-SCOPE video output, and will therefore always display whatever video is input to the V-SCOPE. The V-SCOPE dedicated monitor is connected to the full-time output, and will always display V-SCOPE synthesized waveform/vector information.

Figure 4-2 V-SCOPE with dedicated monitor

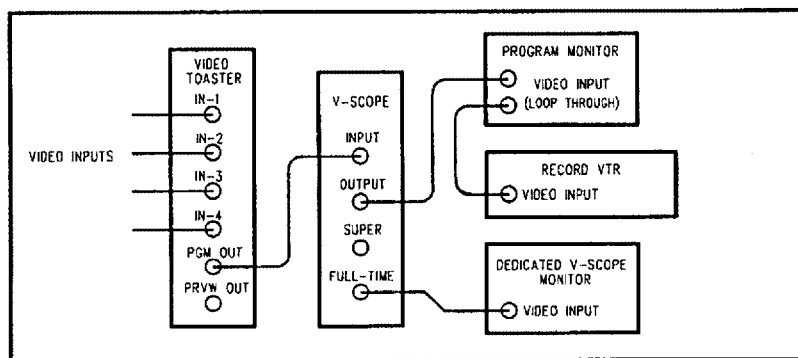

Chapter Five : V-SCOPE Control Software

The control software for the Personal V-SCOPE allows the various operating modes and features of the card to be selected. The V-SCOPE is supplied with software for use on the AMIGA computer. Contact DPS for information regarding software for IBM PC type, DOS or Windows machines. The AMIGA software consists of two programs for controlling the V-SCOPE. One, the TBC-II program, provides integrated control of both DPS Personal TBC-II's and the V-SCOPE. If you have one or more DPS Personal TBC-II's, then you should use this program. The V-SCOPE program, also supplied with the card, provides control of the V-SCOPE only.

Installation

From the workbench screen on the AMIGA.

1. Insert the supplied micro-floppy DPS Personal V-SCOPE disk in df0: on the AMIGA.
2. When the ICON appears for the V-SCOPE disk, double click on it to open the V-SCOPE disk.
3. Double click on the Install icon, and follow the instructions provided.

Integrated V-SCOPE and TBC-II Control

The V-SCOPE is supplied with two control programs. The TBC-II version is intended for integrated control of DPS Personal TBC-II cards, and V-SCOPE cards. If you do not have a TBC-II, you should use the V-SCOPE version of the program. The TBC-II program has an area of the screen which is dedicated to controlling the V-SCOPE. This area is called the V-SCOPE control panel, and is shown in figure 5-1. This control panel is identical to the V-SCOPE control panel presented by the stand alone V-SCOPE program, and its operation is described in the next section.

Stand Alone V-SCOPE Control Program

The V-SCOPE program supplied on the V-SCOPE distribution disk is intended for use in systems that do not have DPS Personal TBC-II's. When run, the V-SCOPE program produces the V-SCOPE control panel shown in figure 5-1 below.

Figure 5-1 V-SCOPE Control Panel Software

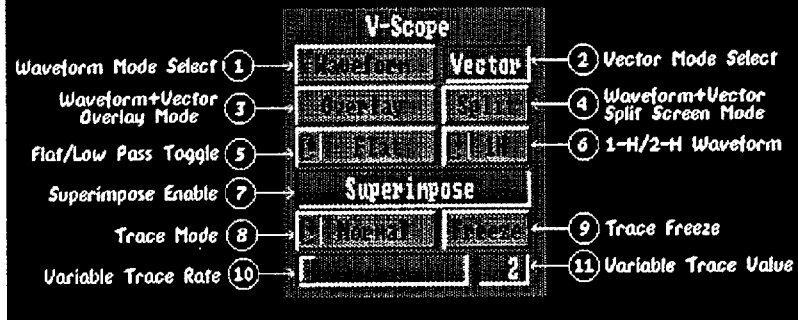

The following section describes the function of each of the items on the V-SCOPE control panel.

1 - Waveform Mode Select Gadget

When this gadget is selected, the V-SCOPE is placed in full screen waveform display mode.

2 - Vector Mode Select Gadget

When this gadget is selected, the V-SCOPE is placed in full screen vector scope mode.

3 - Waveform+Vector Overlay Gadget

When this gadget is selected, the V-SCOPE is placed in full screen waveform + vector scope overlay mode. This produces a display with both full screen waveform monitor and full screen vector scope simultaneously displayed.

4 - Waveform+Vector Split Screen Gadget

When this gadget is selected, the V-SCOPE is placed in waveform + vector scope split screen mode. This produces a display in which the top half of the screen shows live video, and the bottom half of the screen consists of a quarter sized waveform monitor display, and a quarter sized vector scope display placed side by side.

5 - Flat/Low Pass Cycle Gadget

This gadget cycles the V-SCOPE waveform monitor between flat and low pass frequency response modes. The low pass mode is normally used when setting white or black levels while viewing the V-SCOPE waveform monitor display. This mode eliminates most of the chrominance and high frequency noise which allows for more accurate settings. See chapter seven for more details.

6 - 1-H/2-H Waveform Cycle Gadget

This gadget cycles the V-SCOPE waveform monitor between 1-H (single video line) and 2-H (dual video line) display modes. Note: The 2-H mode is not allowed when the V-SCOPE is in split screen mode. Normally, the 1-H mode is used, as this provides the best display resolution. The 2-H mode is used when it is desirable to view the horizontal blanking interval (see chapter seven) of the video signal.

7 - Superimpose Enable Gadget

When this gadget is selected, the superimpose output from the V-SCOPE card will be enabled, and will contain the synthesized waveform/vector display as determined by the other gadgets. When this gadget is de-selected, the superimpose output will contain a copy of the V-SCOPE video input signal.

8 - Trace Mode Cycle gadget

The trace mode cycle gadget determines the trace mode for the V-SCOPE synthesized beam. When **Normal** is selected, the V-SCOPE display is updated every two frames, with old data being erased. When **Peak Hold** is selected, the old data is NOT erased, and a cumulative display results, which will show all peak video excursions. When **Variable** is selected, the display update rate may be changed by moving the variable trace rate slider. Increasing the rate will produce a display which is more fully 'colored in'. This can improve the readability in certain modes (such as waveform+vector overlay, with 2-H selected).

9 - Trace Freeze Gadget

This gadget freezes the V-SCOPE trace, providing an instantaneous 'snap shot' of the current waveform/vectors being displayed.

10 - Variable Trace Rate Slider

This slider is used set the variable trace update rate whenever the trace mode cycle gadget is in the variable setting.

11 - Variable Trace Value

This gadget provides a numerical read out (the actual trace update rate in frames) of the variable trace rate selected by the variable trace rate slider.

Chapter Six : Personal TSG Software

The Personal TSG software included on the V-SCOPE distribution disk is used to create industry standard video test signals with a video toaster. The software creates files in the video toaster frame format, which may be loaded directly from the toaster switcher screen. The video test signals generated by these files (when loaded into the video toaster) may be used in conjunction the V-SCOPE to preform a wide variety of video system measurement, calibration and alignment procedures.

Installation

The personal TSG software is automatically installed as part of the basic V-SCOPE installation procedure outlined in chapter 5.

Running the Personal TSG Software

To use the Personal TSG software to generate video test signals, you must first run the TSG program, by double clicking its icon. Then, follow the instructions provided by the program. The TSG software will create a file for each of the video test signals you select. This file will be in the video toaster frame format, and will be located in the Dh0:Framestore directory (where all video toaster framestore files live) of your hard disk.

Toaster Vers 1.x vs Vers 2.x

One of the options provided by the TSG software allows you to modify the video test signals for toaster version 2.x. If you are using toaster version 2.x then you should select this option. This is because the version 2.x software allows for longer video lines (752 samples vs 736 samples under version 1.x). When this option is selected, the TSG software will modify the test signal data to take advantage of this, and as a result will produce signals which more precisely match industry standards. (Note: files generated for toaster version 1.x will load under version 2.x, but files generated for version 2.x will not load under version 1.x).

Displaying the Test Signals

To use the video test signal files produced by the Personal TSG software, you have to load them into the video toaster frame buffer. To do this, run the video toaster as you normally would. When the switcher screen appears, click on the toaster frame load icon (located just above the TAKE button on the switcher screen). Next, click on the frame number box (just above the frame load icon) and hold down the mouse button while dragging the mouse so that the number displayed changes. When you get to the number range for the test signal files (default is 800), you will see the names of the test signal files appearing in the box just above the frame number. Release the mouse button when the name for the test signal you want appears in the box (eg; SMPTE_Bars). Next, double click on the frame load icon, this will load the file selected into the toaster frame buffer (DV1 or DV2). Then, on the program buss, select either DV1 or DV2 to display the video test signal.

List of Personal TSG Test Signals

The table below lists each of the video test signals generated by version 1.10 of the DPS Personal TSG software.

<u>File Name</u>	<u>Test Signal Name</u>	<u>Usage</u>
800.fs.SMPTE_Bars.....	SMPTE color bars	1,2,3
801.fs.EIA_Bars.....	EIA color bars	1,2,3
802.fs.FF_Bars.....	Full Field color bars.....	1,2,3
803.fs.Bars_Luma.....	Bars/Luminance bars	1,2,3
804.fs.Bars_Red.....	Bars/Red bar	2,3,10
805.fs.Bars_Reverse.....	Bars/Reverse bars	2,3,11
806.fs.Bars_Timing.....	Bars + Mod. timing pulses.....	2,3,12
807.fs.Luma_Bars.....	Luminance only bars.....	2
808.fs.MBurst_60.....	Multi-Burst 60 IRE pk-pk	2,4
809.fs.MBurst_100.....	Multi-Burst 100 IRE pk-pk.....	2,4
810.fs.Luma_Sweep.....	Luma freq. sweep 0-4.2 MHz.....	4
811.fs.Chroma_Sweep....	Chroma freq. sweep 0-500 KHz ...	4
812.fs.Pulse_&_Bar.....	Pulse & Bar	5
813.fs.Conv_Grid.....	Convergence grid	1
814.fs.Black.....	Black field (7.5 IRE)	9
815.fs.Gray.....	Gray field (50 IRE)	13
816.fs.White.....	White field (100 IRE)	2
817.fs.Red_Field.....	Red field (75% saturation).....	10

<u>File Name</u>	<u>Test Signal Name</u>	<u>Usage</u>
818.fs.Mod_5_Step	Modulated 5 step	6,7
819.fs.Luma_5_Step	Luminance 5 step	6
820.fs.Mod_Ramp	Modulated ramp	6,7
821.fs.Luma_Ramp	Luminance ramp	6
822.fs.Multi_Ramp	Demod. alignment ramps	3
823.fs.FCC_Comp	FCC composite test signal	2,5,6,7,12
824.fs.NTC7_Comb	NTC7 combination waveform	4,6
825.fs.Multi_Pulse	Multi-Pulse	8
826.fs.Sin(X)_X	Sin(x)/x pulses	8
827.fs.Matrix_1	Matrix signal 1	13
828.fs.Matrix_2	Matrix signal 2	13
829.fs.Matrix_3	Matrix signal 3	13
830.fs.Matrix_4	Matrix signal 4	13
831.fs.Matrix_5	Matrix signal 5	13

Usage Codes:

- 1.....Picture monitor alignment.
- 2..... Video levels (waveform monitor).
- 3..... Chroma level/phase (vector scope).
- 4..... Frequency response (waveform monitor).
- 5..... K-Factor (waveform monitor).
- 6..... Linearity (waveform monitor).
- 7..... Differential Phase/Gain (vector scope).
- 8..... Group delay (waveform monitor).
- 9..... Luminance Signal-to-Noise ratio.
- 10..... Chrominance Signal-to-Noise ratio.
- 11..... VTR Velocity error (vector scope).
- 12..... Y/C Delay (waveform monitor).
- 13..... General usage.

The next chapter of this manual describes how to use the video test signals in conjunction with the V-SCOPE to make video measurements.

Chapter Seven : Video Measurements

This chapter describes how to make video measurements using the V-SCOPE with various video signals (such as the test signals generated by the Personal TSG software).

V-SCOPE Waveform Mode

The V-SCOPE waveform mode is used to measure video signal levels. Figure 7-1 below shows the V-SCOPE display in waveform mode with a full field luminance only bars signal as input (Personal TSG pattern 807.fs.Luma_Bars). (Note, to obtain this display you must select Waveform mode, 1-H and FLAT on the V-SCOPE control screen).

IRE Units

The vertical axis on the left-hand side of the V-SCOPE display is calibrated in IRE units. These IRE units are used to express video levels. The 0 IRE level is referred to as the blanking level. This is the level that the video signal is normally at during the non-displayed portions of the video waveform. The 100 IRE level corresponds to white. This is normally the highest level that the luminance (or black and white) portion of the video signal should be. The 7.5 IRE level, as indicated by the dotted line on figure 7-1, corresponds to black. This is the correct level for the darkest portions of video signal. The -40 IRE level is the sync. tip level. This is the correct level for the bottom of the horizontal sync. pulse. The vertical axis on the right-hand side of the V-SCOPE is calibrated in millivolts (mv). This scale represents an alternative method for expressing video signal levels. As can be seen from the figure, the overall amplitude of the video signal ranges from -286mv to +714mv or 1000mv (= 1 Volt) peak-to-peak.

The Horizontal Blanking Interval

Figure 7-1 below shows the V-SCOPE display in waveform mode with a full field luminance only (or black and white) bars signal as input (Personal TSG pattern 807.fs.Luma_Bars). The V-SCOPE waveform mode displays one full line of video information. At the beginning of each video line is the horizontal blanking interval. This portion of the video signal is not normally displayed. It is composed of the horizontal sync. pulse, followed by the color burst. The horizontal sync. pulse is used as a timing reference for the video signal. The color burst is defined as 9 cycles at 3.58 MHz (the color subcarrier frequency).

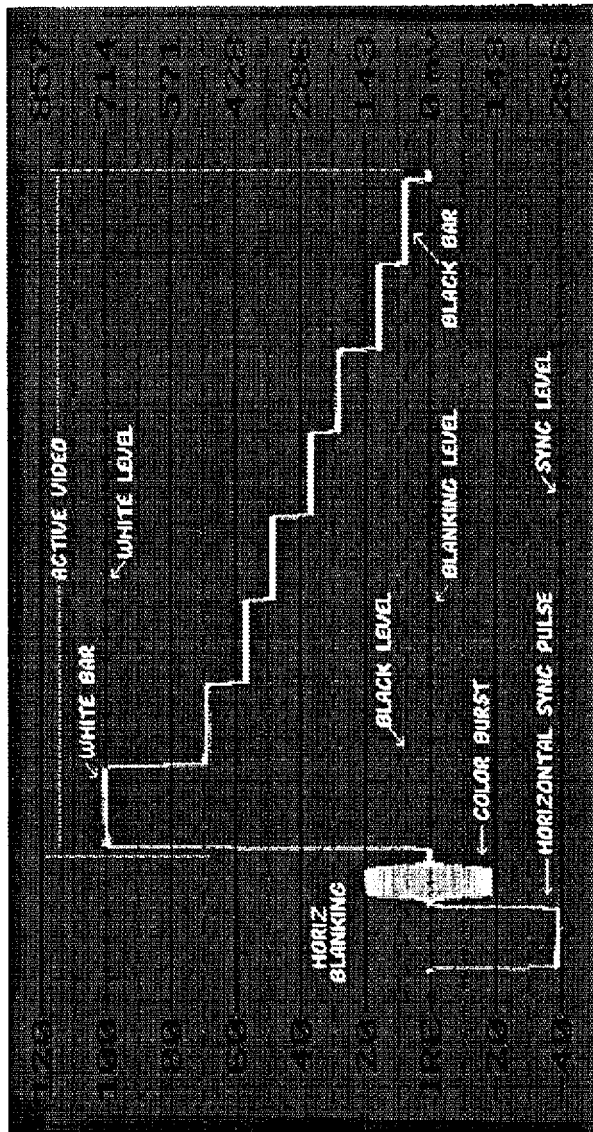

Figure 7-1 V-SCOPE Waveform mode (Luminance only bars)

This color burst (usually just called 'the burst') is used as a synchronizing signal for circuits which demodulate the color information in the video signal. (Note that the signal in figure 7-1 does not have any color).

The Active Video Interval

The portion of the video signal beginning after the color burst, and lasting to the end of the video line is called the active video. This is the section of the waveform which is actually displayed. The luminance only bars signal of figure 7-1 consists of 8 equal length bars of decreasing luminance (or brightness). The first bar, displayed at the left side of the picture, is the white bar. Note that this bar has a level of 100 IRE. The next six bars are of progressively lower luminance values as indicated in the figure. The last bar is the black bar. Note that it has a level of 7.5 IRE.

Full Field Color Bars Signal

Figure 7-2 below shows the V-SCOPE display in waveform mode with a full field color bars signal as input (Personal TSG pattern 802.fs.FF_Bars). This is the same signal as in figure 7-1, but now we have added color to the six middle bars of the signal. Note that in the waveform mode, each of the colored bars look similar. This is because the color information is carried by a 3.58 MHz subcarrier which is added to the black and white (or luminance) signal to produce color. The particular amplitude and phase of this color subcarrier is what determines color. The V-SCOPE vector scope mode provides a method for viewing color signals with more detail. Also note that the first two colored bars, yellow and cyan, have a peak amplitude which is equal to the white level (100 IRE). This provides a quick check that the color or chrominance amplitude is correct (though this may be more accurately set using the vector scope mode).

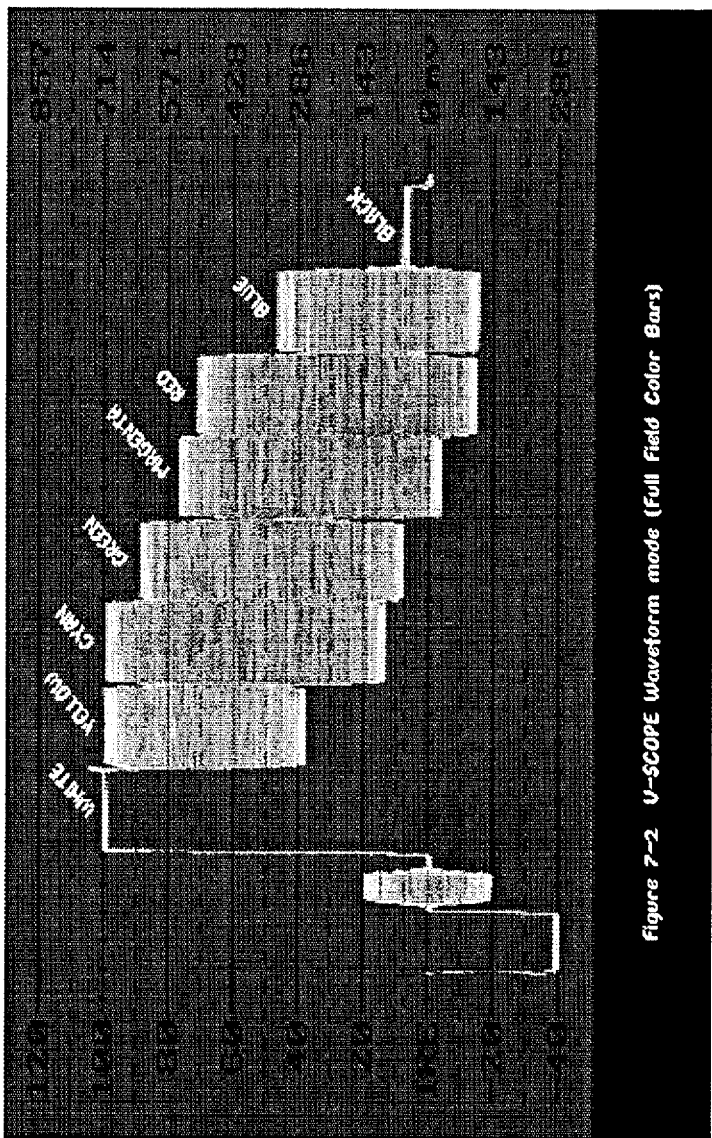

Figure 7-2 U-SCOPE Waveform mode (Full Field Color Bars)

SMPTE Color Bars Signal

Figure 7-3 below shows the V-SCOPE display in waveform mode with a SMPTE color bars signal as input (Personal TSG pattern 800.fs.SMPTE_Bars). The SMPTE color bar test signal is one of the most frequently used video test signals. It is composed of three separate signals which occupy different regions of the screen. These three signals appear on top of one and other on the V-SCOPE waveform display of figure 7-3. The top two-third of the screen contain the seven bar standard color bars signal. This is similar to the full field color bar signal of figure 7-2, but there is no black bar, and the first bar of the SMPTE bars is at 77 IRE not 100 IRE. The next one-twelfth of the screen contains the reverse blue bar signal. The bottom quarter of the screen contains -I, White, Q and black set signals. The various elements of the SMPTE color bar waveform make this signal useful for video level adjustments as well as picture monitor alignment. As with the full field color bar signal, the chrominance adjustments are best made using the V-SCOPE vector scope mode. The V-SCOPE waveform mode should be used to observe the white ref. portion of the signal is at 100 IRE (or white). The black level of the signal may also be aligned to the 7.5 IRE dotted line on the V-SCOPE graticule using the black level control on your video proc. amp.

Using SMPTE Color Bars for Monitor Alignment

One of the uses for the SMPTE color bar test signal is the alignment of picture monitor chroma, hue and black level adjustments. The chroma gain and hue controls are set by comparing the blue chrominance from the color bars (top 2/3 of the screen) to the blue chrominance of the reverse color bars (middle section of the SMPTE color bar signal). In order to perform this procedure, you must first switch off the green and red guns on your picture monitor (or select the blue only mode if your monitor has this feature). The actual procedure is outlined below:

- 1) Turn off the green and red guns (or select blue only mode) on your picture monitor.
- 2) Compare the extreme right or left bar with the reverse bar segment directly below it. Adjust the monitor chroma control until there is no visible difference.

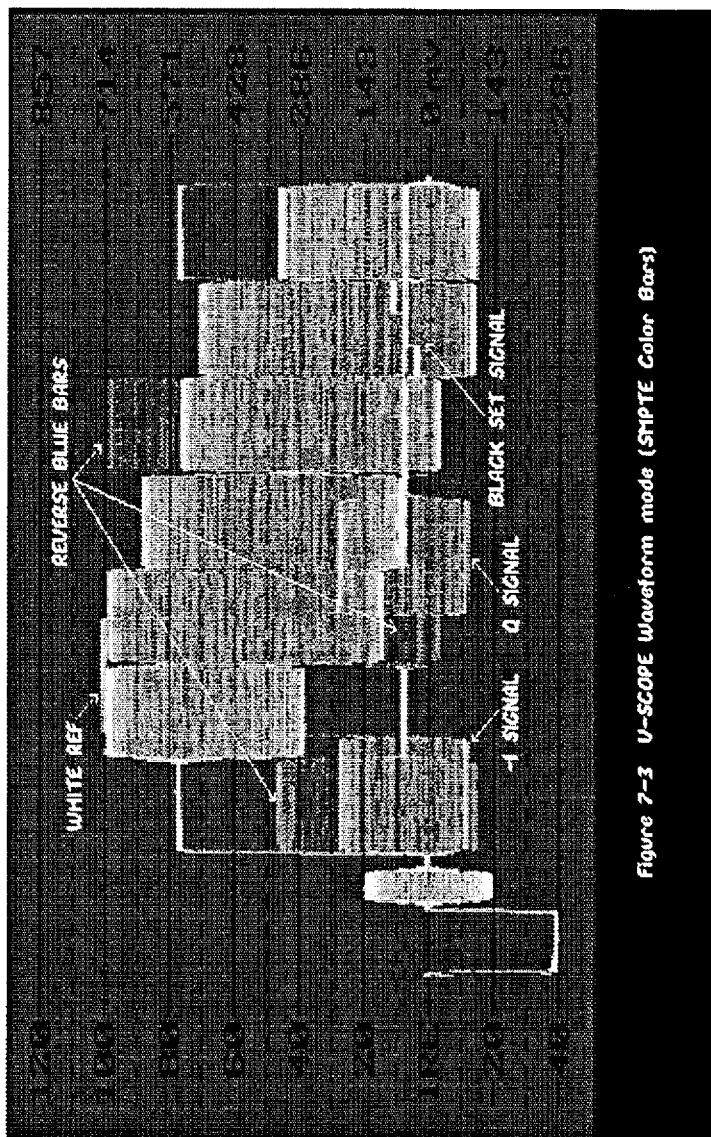

Figure 7-3 U-SCOPE waveform mode (SHIPTE Color Bars)

<u>File Name</u>	<u>Test Signal Name</u>	<u>Usage</u>
818.fs.Mod_5_Step	Modulated 5 step	6,7
819.fs.Luma_5_Step	Luminance 5 step	6
820.fs.Mod_Ramp	Modulated ramp	6,7
821.fs.Luma_Ramp	Luminance ramp	6
822.fs.Multi_Ramp	Demod. alignment ramps	3
823.fs.FCC_Comp	FCC composite test signal	2,5,6,7,12
824.fs.NTC7_Comb	NTC7 combination waveform	4,6
825.fs.Multi_Pulse	Multi-Pulse	8
826.fs.Sin(X)_X	Sin(x)/x pulses	8
827.fs.Matrix_1	Matrix signal 1	13
828.fs.Matrix_2	Matrix signal 2	13
829.fs.Matrix_3	Matrix signal 3	13
830.fs.Matrix_4	Matrix signal 4	13
831.fs.Matrix_5	Matrix signal 5	13

Usage Codes:

- 1.....Picture monitor alignment.
- 2.....Video levels (waveform monitor).
- 3.....Chroma level/phase (vector scope).
- 4.....Frequency response (waveform monitor).
- 5.....K-Factor (waveform monitor).
- 6.....Linearity (waveform monitor).
- 7.....Differential Phase/Gain (vector scope).
- 8.....Group delay (waveform monitor).
- 9.....Luminance Signal-to-Noise ratio.
- 10.....Chrominance Signal-to-Noise ratio.
- 11.....VTR Velocity error (vector scope).
- 12.....Y/C Delay (waveform monitor).
- 13.....General usage.

The next chapter of this manual describes how to use the video test signals in conjunction with the V-SCOPE to make video measurements.

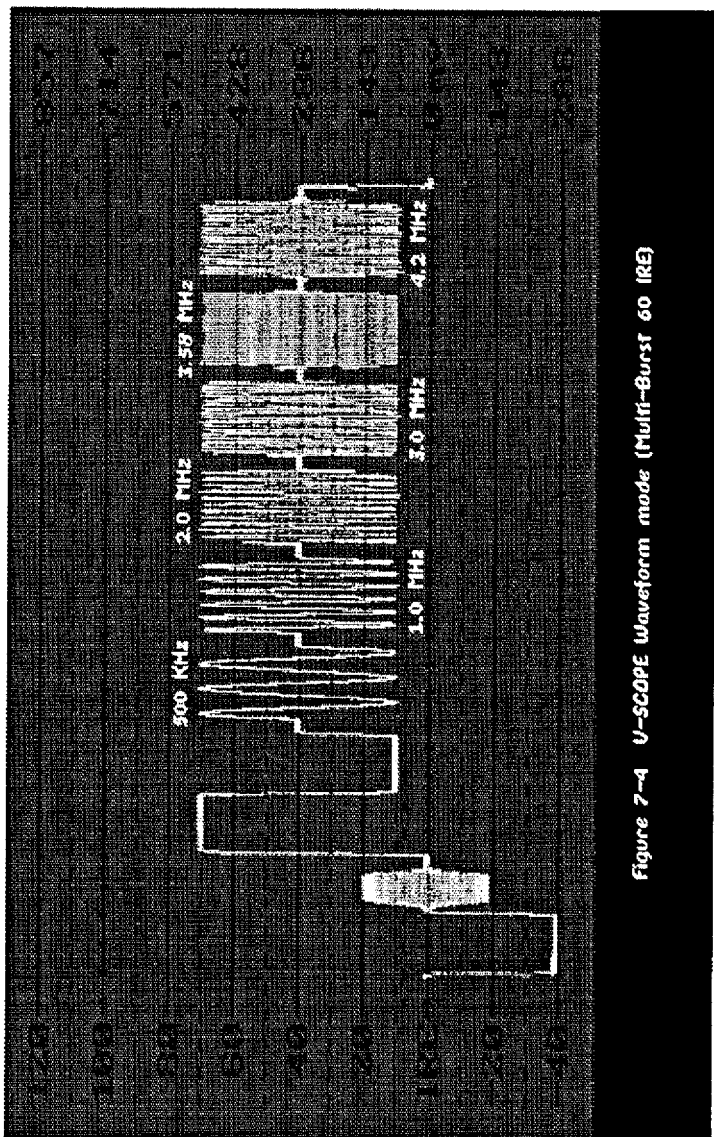

Figure 7-4 U-SCOPE waveform mode (Multi-Burst 60 IRE)

The Pulse and Bar Test Signal

Figure 7-5 below shows the V-SCOPE display in waveform mode with a pulse and bar signal as input (Personal TSG pattern 812.fs.Pulse_&_Bars). The pulse and bar signal consists of three parts. The first part is called the 12.5T modulated pulse. The 12.5T refers to the duration of this pulse, where $T = 125$ nsec. This is called a modulated pulse because it is derived by adding a modulated chrominance signal to a luminance pulse to obtain the waveform shown in figure 7-5. This modulated pulse is normally used to measure Y/C delay. (Note: Y/C delay is an artifact that is introduced by a video system when the luminance (or Y) signal is delayed by a different amount than the chrominance (or C) signal). When this modulated pulse is processed through an ideal system, one with 0 Y/C delay, the bottom of the pulse will remain flat, as shown in the figure. If however, the system has a significant Y/C delay distortion, then the bottom of the pulse will become 'S' shaped. The more pronounced this 'S' shape is, the larger the Y/C delay distortion. The second part of the pulse and bar signal is the 2T pulse. This pulse is a luminance only signal with a half amplitude duration of 2T (or 250 nsec). It is used to determine the response of a video system to high speed edges. When applied to an ideal system, the overall amplitude of the pulse should remain equal to the height of the bar signal, and there should be minimal preshoot and overshoot at the beginning and end of the pulse. This pulse can be used in conjunction with a device for measuring K-Factor, which is a video specification that refers to the amount of preshoot or overshoot exhibited by a piece of equipment. For broadcast quality devices, this overshoot should be less than 1% of the overall pulse height. The final part of the pulse and bar signal is the bar. This section of the waveform is used to measure low frequency distortions in a video signal. The top of the bar signal should be flat. If it is tilted, then this distortion is referred to as bar tilt, and indicates a low frequency error. The bar signal also contains an inverted 2T pulse for use in K-Factor measurements.

The Convergence Grid Signal

The convergence grid test signal (Personal TSG signal 813.fs.Conv_Grid) is used for picture monitor convergence alignment. When applied to a picture monitor, this signal produces a grid of white squares on a black background.

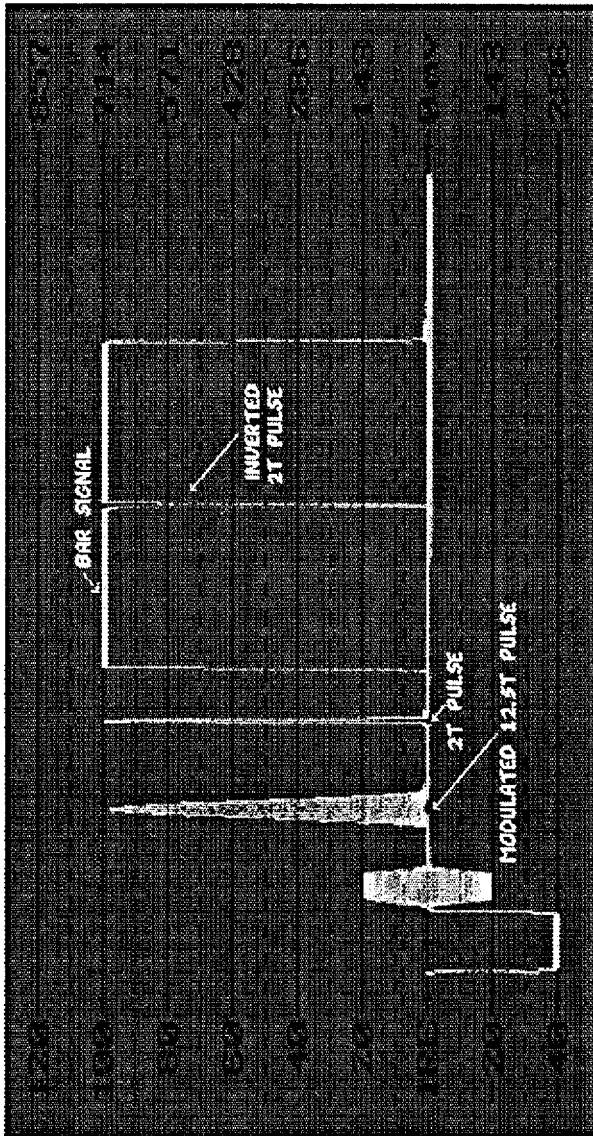

Figure 7-5 USCOPE Waveform mode (Pulse & Bar Signal)

If the convergence of the monitor is off, then some of the white lines will separate into green, red and blue (this is typically most evident near the corners of the picture). If your monitor has convergence alignment controls, then these may be used to minimize the problem.

V-SCOPE Vector Scope Mode

The V-SCOPE vector scope mode is used to examine the chrominance or color parts of a video signal. The basic vector scope display is shown in figure 7-6 below with a full field color bar input signal (Personal TSG signal 802.fs.FF_Bars). The vector scope mode works by demodulating the chrominance signal into separate R-Y and B-Y color difference signals. These color difference signals are a method of representing color independent of brightness or luminance. That is, all possible chrominance values can be obtained by mixing different amounts of R-Y and B-Y. Also, any signal with zero R-Y and zero B-Y will be a black and white (or luminance only) signal. When combined with the luminance (or Y signal) the R-Y, B-Y and Y signals completely describe the video signal (in much the same way as separate R, G and B would). When displayed on the vector scope, the R-Y signal is used as the vertical axis, and the B-Y signal is used as the horizontal axis. All values of chrominance are then located somewhere within the circle on the vector scope graticule. For instance, the color burst signal is defined to be located on the - (B-Y) axis, as shown in the figure. One of the most useful features of the vector scope are the color bar targets. These square boxes located on the graticule, and labelled in figure 7-6, are the correct locations for each of the six vectors produced by a color bar test signal. When adjusting a color bar signal, the vector scope mode should be used to set the correct chrominance level (distance of each vector from the origin) and the hue (which rotates the vector display) so that each of the color bar vectors fall inside of the vector targets. Figure 7-6 also shows the locations of the -I axis and the Q axis. When the V-SCOPE is processing a SMPTE color bar signal, there will be a vector produced along each of these two axes (as a result of the -I and Q signal present in the SMPTE color bar signal, see figure 7-3), in addition to the color bar vectors.

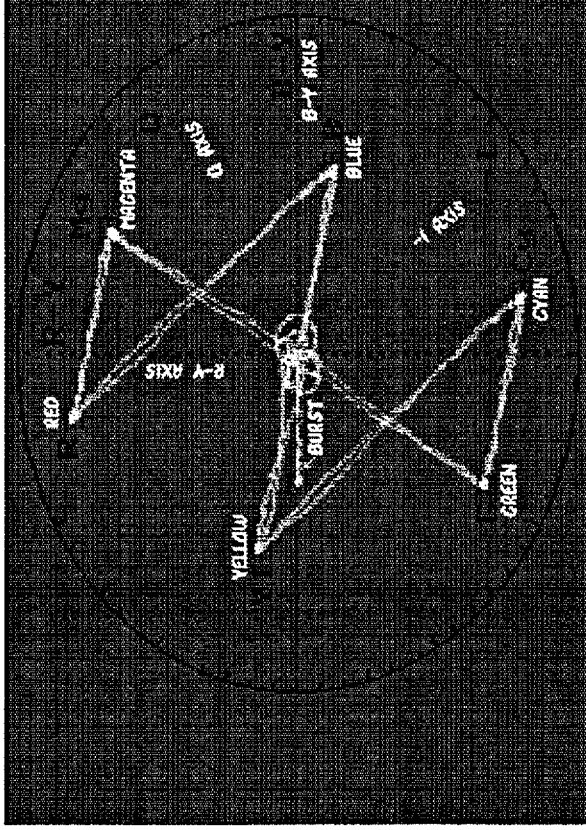

Figure 7-6 U-SCOPE Vector Scope mode (Full Field Color Bars)

V-SCOPE Waveform/Vector Scope Overlay Mode

Figure 7-7 below shows the V-SCOPE in overlay mode. This allows for simultaneous full screen display of both vector scope and waveform information.

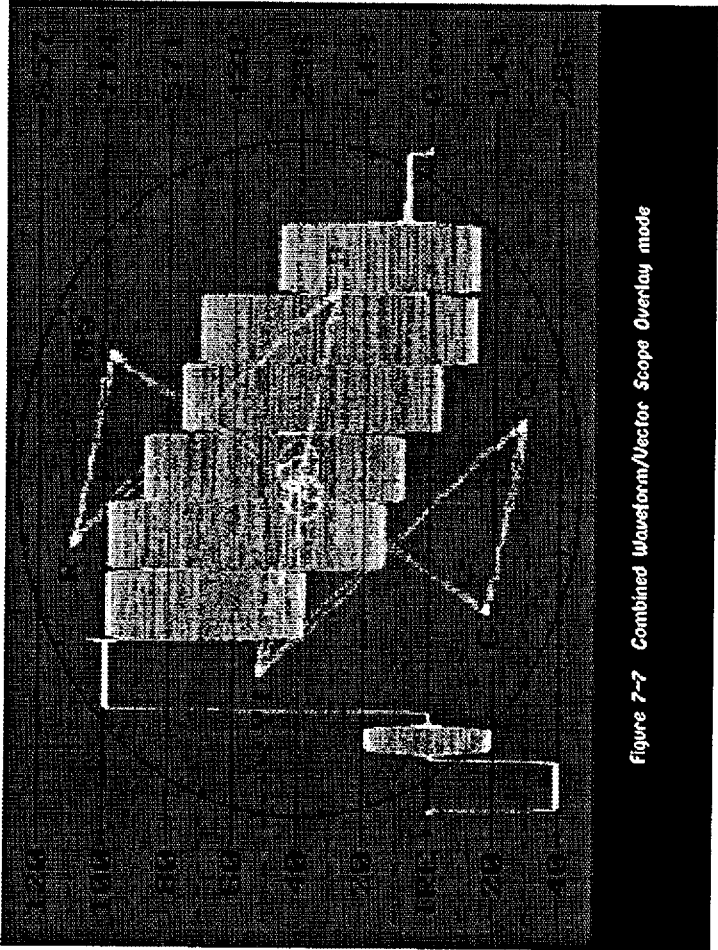

Figure 7-7 Combined Waveform/Vector Scope Overlay mode

V-SCOPE Waveform/Vector Scope Split Screen Mode

Figure 7-8 below shows the V-SCOPE in split screen mode. This allows for both vector scope and waveform information on the bottom half of the screen, with live video on the top half.

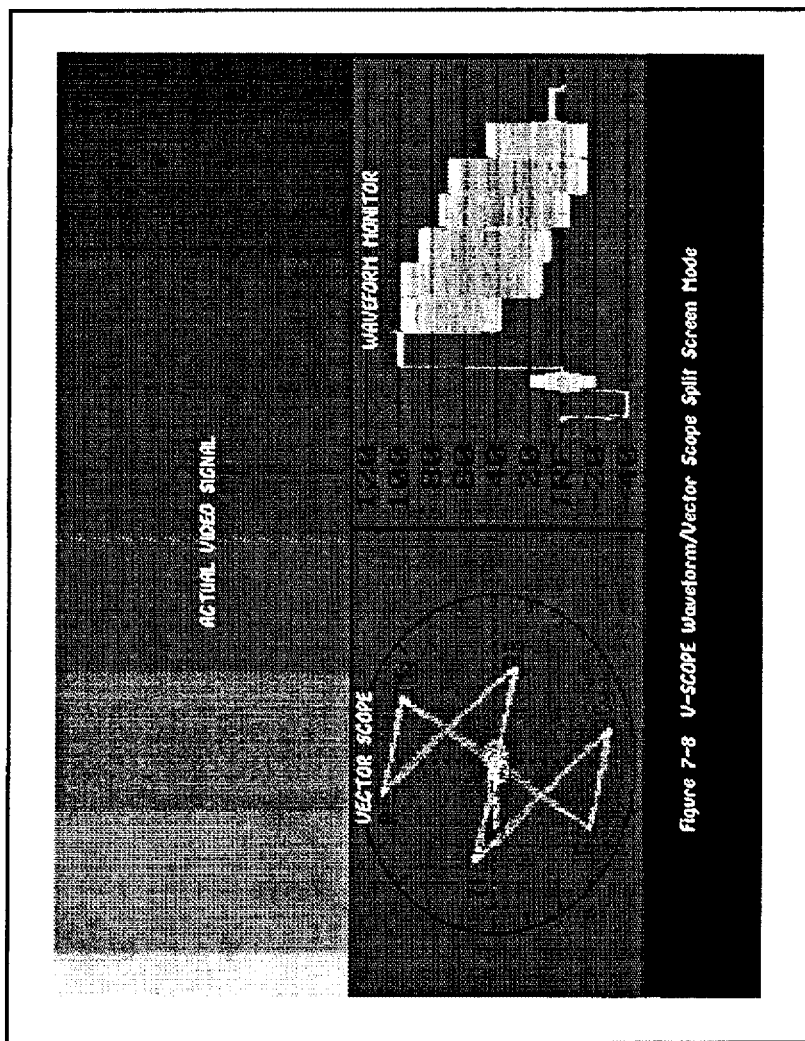

Figure 7-8 V-SCOPE Waveform/Vector Scope Split Screen Mode

Processing Live Video

Whenever you create a new video tape, either as a dub of an existing tape, or as live footage shot with a camcorder, you should always record about 30 seconds of color bars at the beginning of the tape. Then, when you want to use this tape as part of a video production, you can play the color bar section at the beginning of the tape, and use the techniques outlined earlier in this chapter to correctly adjust the video signal levels using the V-SCOPE to monitor the playback color bar signal. After performing this alignment, you should always examine some of the actual footage using the V-SCOPE waveform monitor to check that the video levels recorded on the tape are consistent with those indicated by the color bars. When viewing actual live video using the V-SCOPE waveform mode, it is sometimes useful to use the V-SCOPE Low Pass mode. This mode is engaged by clicking on the Flat/Low Pass toggle button on the V-SCOPE control screen. When the low pass mode is selected, the frequency response of the V-SCOPE becomes rolled off above 1 MHz so that the true luminance levels may be more easily viewed. Figure 7-9 below shows an actual live video signal displayed on the V-SCOPE in the FLAT or full bandwidth mode. Figure 7-10 shows the same signal, but this time in the low pass mode. Note that the peak white and black levels are much easier to determine in the low pass mode.

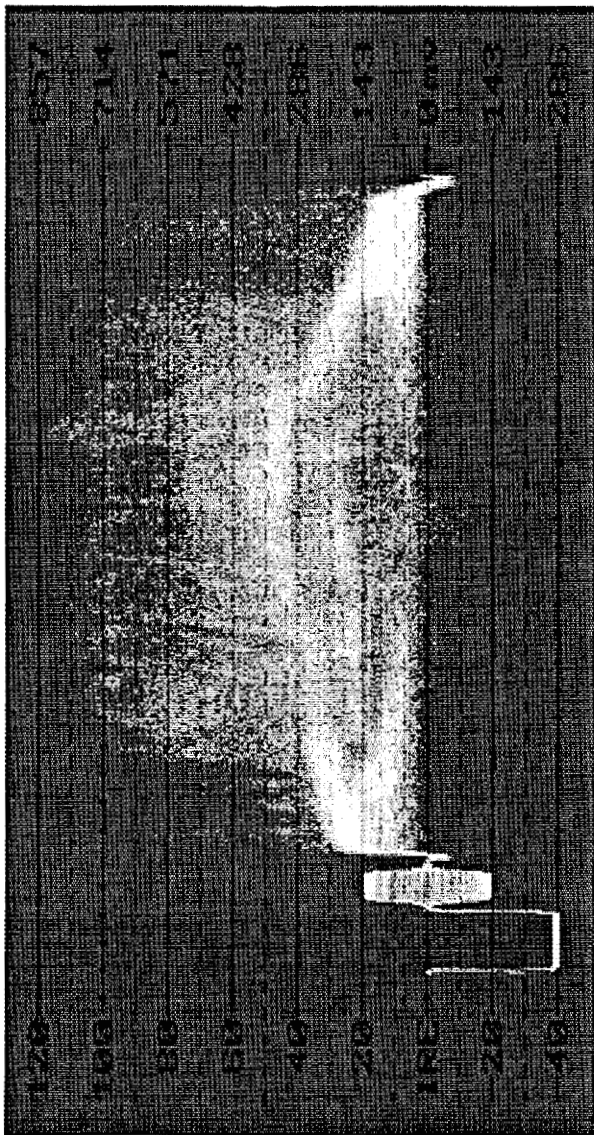

Figure 7-9 V-SCOPE Waveform Mode, Live Video, FLAT Mode

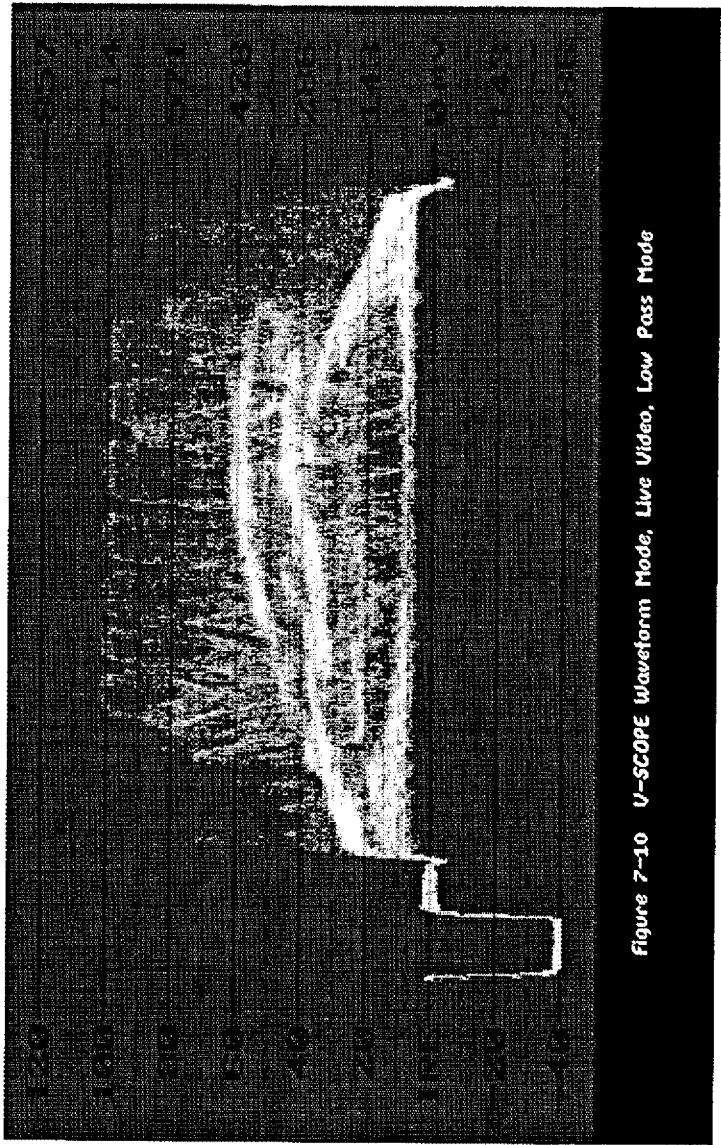

Figure 7-10 V-SCOPE Waveform Mode, Live Video, Low Pass Mode

Chapter Eight: Specifications

Video Input.....	1 V p-p, 75 Ohms
Video Output.....	1 V p-p, 75 Ohms
Frequency Response	+/- 0.25 dB to 5.5 MHz -3 dB @ 6 MHz
Accuracy.....	< 1% of full scale
Differential Phase	< 2 Deg
Differential Gain	< 2 %
Superimpose Output*.....	1 V p-p, 75 Ohms
Dedicated Output*	1 V p-p, 75 Ohms
Power Consumption	10 Watts +5V @ 560 mA +12V @ 500 mA -12V @ 100 mA
Serial Data Input	RS-232 Levels 9.6/31.25 KBPS

* Color or B&W jumper selectable.

Appendix A: Using an Expansion Serial Board

The control software for the Personal V-SCOPE requires that the V-SCOPE be connected to a serial port on the AMIGA. This is normally the built in serial port on the AMIGA mother board. If the serial port on your AMIGA is already in use then it may be necessary to use an expansion serial board such as the Commodore A2232 (or equivalent) multi-serial card. Note that in most cases the built in serial port may be shared between other tasks and V-SCOPE control. This is because the V-SCOPE uses a 'listen only' type of serial interface which allows the V-SCOPE internal serial connection to be maintained, even while some other task, such as a serial print or modem, is connected to the external DB-25 connector on the AMIGA. In cases where the built in AMIGA port cannot be shared, it will be necessary to interface to the V-SCOPE using an expansion serial card. The following instructions are provided to assist you in using such a device.

Commodore® A2232 Serial Card

To use the commodore A2232 card to control the V-SCOPE perform the following steps:

- 1) Install the A2232 card in your computer as detailed in the instructions accompanying the card.
- 2) Run the A2232 install program provide with the A2232 board.
- 3) Locate the Personal TBC-II (or V-SCOPE) icon on your workbench screen. Click on the icon so that it becomes highlighted. The push and hold the right mouse button and drag down the workbench menu, and select the info item.
- 4) At the tool types area of the info screen, use the scroll gadget to select the 'UNIT=' tool type. Edit this entry to select the unit number associated with the serial port on the A2232 card you want to use (refer to the A2232 documentation).
- 5) Use the scroll gadget to select the 'BAUD=' tool type. Edit this entry to 9600 (Note: the A2232 does not support the default 31.25 KBPS rate used by the V-SCOPE card).
- 6) Select the Save item on the info screen.
- 7) On the V-SCOPE card, put DIP Switch 1 in the down position to select 9600 BPS operation (see figure 2-1).

ASDG[®] Dual Port Serial Board

To use the ASDG Dual port serial board to control the V-SCOPE perform the following steps:

- 1) Install the ASDG card in your computer as detailed in the instructions accompanying the card.
- 2) Run the ASDG install program provide with the board.
- 3) Locate the Personal TBC-II (or V-SCOPE) icon on your workbench screen. Click on the icon so that it becomes highlighted. The push and hold the right mouse button and drag down the workbench menu, and select the info item.
- 4) At the tool types area of the info screen, use the scroll gadget to select the 'DEVICE=' tool type. Edit this entry to 'DEVICE=siosbx.device'. **Note:** this entry is case sensitive so be sure to enter the device name in lower case.
- 5) Use the scroll gadget to select the 'UNIT=' tool type. Edit this entry to select the unit number associated with the serial port on the ASDG card you want to use (refer to the ASDG documentation).
- 6) Select the Save item on the info screen.

Appendix B: Troubleshooting

General

When a problem occurs in a complex setup involving multiple pieces of video equipment, always try to reduce the complexity of the setup by disconnecting pieces of equipment until you can obtain a minimum configuration which still exhibits the problem. For the V-SCOPE card, connect a known good video signal directly to the video input, and a picture monitor directly to the video outputs. This will let you see if the V-SCOPE is correctly processing video, independent of other equipment in your system. Also, the V-SCOPE on-board DIP switches may be used to manually change modes (see chapter two) independent of the control software.

V-SCOPE Software

If the V-SCOPE hardware seems to be functioning correctly, but the card does not respond to the V-SCOPE software, then try to connect the V-SCOPE directly to the AMIGA serial port using the external DB-25 to RJ-14 serial cable (if you are not already using this cable). Also, make sure the V-SCOPE on board serial DIP switch (see figure 2-1) is set in the correct position (normally Up=31.25 KBPS for the AMIGA built in serial port).

Appendix C: V-SCOPE Software Protocol

This appendix describes the serial data interface to the V-SCOPE. The information presented here is intended for users/programs who want to develop their own custom driver software for the V-SCOPE.

Electrical Interface

The electrical interface is RS-232. The bit rate will be 31.25 KBPS or 9600 BPS (DIP switch selectable on the V-SCOPE, see chapter 2), with 8 data bits, 1 stop bit, no parity.

Protocol

The software protocol is a MIDI compatible format, using the system exclusive feature of the MIDI interface. Communication with the V-SCOPE is initiated when the system exclusive command byte (F0 hex) is received, followed by the V-SCOPE id code (67 hex).

The next byte sent is the V-SCOPE address byte (10 hex). This is followed by a V-SCOPE function select byte, and a data byte. The communications is completed when the MIDI end system exclusive byte is sent (F7 hex). The following table summarizes the protocol:

HOST: -> System Exclusive Byte (= F0 hex)
 V-SCOPE ID Byte (= 67 hex)
 V-SCOPE Address Byte (= 10 hex)
 Function Select Byte (= 00-7F hex)
 Data Byte (00-7F hex)
 End System Exclusive (= F7 hex)

System Exclusive Byte

This byte is used in the MIDI protocol to allow manufactures of MIDI equipment to define messages specific to their own equipment. The system exclusive mode remains in effect until the end system exclusive command is sent.

V-SCOPE ID Byte

This byte is the unique code which identifies the exclusive data that follows is the DPS V-SCOPE.

V-SCOPE Address Byte

This byte must be set to 10 hex.

V-SCOPE Function Select/Data Byte

The function byte determines which function on the V-SCOPE will be effected by the command. Most commands follow this byte with one data byte, which represents the new binary value for the selected function. The table below lists each function, and the associated data byte:

<u>Function Byte</u>	<u>Data Byte(s)</u>	<u>Description</u>
01h	1 (0-2)	Set V-SCOPE mode. 00 = Vector Scope mode. 01 = Waveform Display mode. 02 = Overlay Vector/Waveform mode. 03 = Split Screen Vector/Waveform mode.
02h	1 (0-1)	Superimpose Output control. 00 = Superimpose mode OFF. 01 = Superimpose mode ON.
03h	1 (0-1)	1-H/2-H Waveform mode default select. 00 = 1-H Waveform mode. 01 = 2-H Waveform mode.

<u>Function Byte</u>	<u>Data Byte(s)</u>	<u>Description</u>
04h	2 (0-3,02-127)	First Byte: Trace Update mode select. Second Byte: Trace rate (used in mode 3) 0 = Normal. 1 = Freeze Trace. 2 = Peak Hold mode. 3 = Variable rate select.
05h	1 (0-1)	Frequency response select. 0 = Flat response. 1 = Low Pass (Luma) response.

Notes:

For command 04, (Trace mode select) the second byte is used to select the trace update rate (in frames), and will be used whenever mode 3 is selected via the first byte. However, the second byte must always be transmitted no matter which mode is being selected. Selecting a slower update rate (by increasing the value) will cause the display to 'color in' more fully. The default update rate (used in normal mode) is 2 frames.

V-SCOPE ARexx Interface

The Personal V-SCOPE can be controlled using ARexx commands. When the VSCOPE program or the TBC-II program is running, a public message port is opened which responds to ARexx messages in the function call format. The address of this message port depends on which program you are using to run the V-SCOPE. If you are using the stand alone VSCOPE program, then the port address is VSCOPE. If you are using the TBC-II program, then the port address is TBC. In either case, the command format is the same, as described by the table below:

Port Address: VSCOPE or TBC

Command Summary:

<u>Command</u>	<u>Argument(s)</u>	<u>Result</u>
VERSION	< no args >	V-Scope Vx.x NTSC
ANALYZER	[VECTOR WAVE OVERLAY SPLIT] [1H 2H]	returns same
SUPERIMPOSE	[ON OFF]	returns same
EXCITER	[NORMAL FREEZE PEAK VARIABLE]	returns same
RESPONSE	[FLAT LOWPASS]	returns same
RATE	[2 to 127]	returns same

The following code is a sample ARexx program which controls the V-SCOPE. Note, to run this program, the V-SCOPE program must be loaded, and you must have ARexx on your AMIGA.

```
/* V-SCOPE ARexx sample program */
```

```
If ~Show(P, 'VSCOPE') Then Do  
    Say 'VSCOPE program is not loaded'  
    Exit  
End
```

```
Address VSCOPE  
Options Results
```

```
/* Display current settings of V-SCOPE */
```

```
VERSION          ; Say 'Version ID:' Result  
ANALYZER         ; Say 'Analyzer Mode:' Result  
SUPERIMPOSE     ; Say ' Superimpose:' Result  
EXCITER         ; Say ' Beam Exciter:' Result  
RESPONSE        ; Say ' Freq Response:' Result  
RATE            ; Say ' Trace Rate:' Result
```

```
ANALYZER WAVE 1H      /* Set V-SCOPE to 1-H waveform mode */
```

```
End
```

APPENDIX D

FCC Compliance Statement

Warning: Changes or modifications to this unit not expressly approved by the party responsible for compliance could void the user's authority to operate the equipment.

Note: This equipment has been tested and found to comply with the limits for a Class B digital device, pursuant to Part 15 of the FCC rules. These limits are designed to provide reasonable protection against harmful interference in a residential installation. This equipment generates, uses and can radiate radio frequency energy, and, if not installed and used in accordance with the instructions, may cause harmful interference to radio communications.

However, there is no guarantee that interference will not occur in a particular installation. If this equipment does cause interference with radio or television reception, which can be determined by turning the equipment off and on, the user is encouraged to try to correct the interference by one or more of the following measures:

- Reorient the receiving antenna.
- Increase the separation between the equipment and receiver.
- Connect the equipment into an outlet on a circuit different from that to which the receiver is connected.
- Consult a dealer or an experienced Radio/TV Technician for help.

Shielded cables must be used with this unit to ensure compliance with Class A FCC Limits.

FCC ID: I25VM2000PCWVM

This device complies with Part 15 of FCC Rules. Operation is subject to the following two conditions: (1) This device may not cause harmful interference and (2) This device must accept any interference received, including interference that may cause undesired operation.

Appendix E: Warranty

Digital Processing Systems Inc. warrants the original purchaser that this product is in good working condition for a period of two years from the date of purchase. Should this product, in Digital Processing Systems opinion, malfunction within the warranty period, Digital Processing Systems Inc. will repair or replace this product without charge. Any replaced parts become the property of Digital Processing Systems Inc. This warranty does not apply to those products which has been damaged due to accident, unauthorized alterations, repairs or modifications.

Limitations

All warranties for this product, expressed or implied, are limited to two years from the date of purchase and no warranties, expressed or implied, will apply after that period.

The distributor, its dealers and customers agree that Digital Processing Systems Inc. shall not be liable for any loss of use, revenue or profit.

Digital Processing Systems Inc. makes no other representations of warranty as to fitness for purpose of merchantability of otherwise in respect to any of the products sold to the distributor pursuant to this agreement.

The liability of Digital Processing Systems Inc. in respect of any defective products will be limited to the repair or replacement of such products.

In no event shall Digital Processing Systems Inc. be responsible or liable for any damages arising from the use of such defective products whether such damages be direct, indirect, consequential or otherwise and whether such damages are incurred by the distributor or third party.

Warranty Service

Units requiring repair under warranty may be sent directly to Digital Processing Systems Inc. To obtain service under this warranty, first contact:

Digital Processing Systems Inc.
Customer Service Department
(416) 754-8090

and request a Return Material Authorization Number (RMA). This number must be clearly displayed on the units external packaging. Units shipped without an RMA number will not be accepted. Include with the unit, proof of purchase (including date of purchase), a note outlining the problem, and the RMA number.

IMPORTANT: When shipping your unit, pack securely and ship prepaid and insured. Digital Processing Systems Inc. will not be held liable for damage of loss to the product in shipment.

